

SINGLE FAMILY

MULTI-FAMILY

MIXED USE

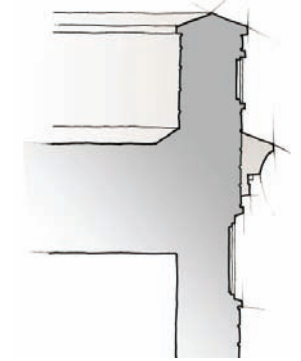
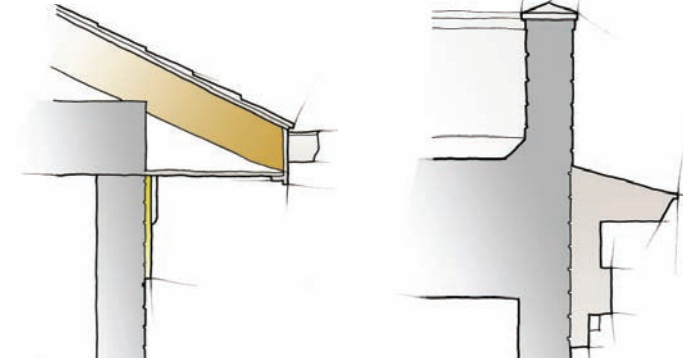
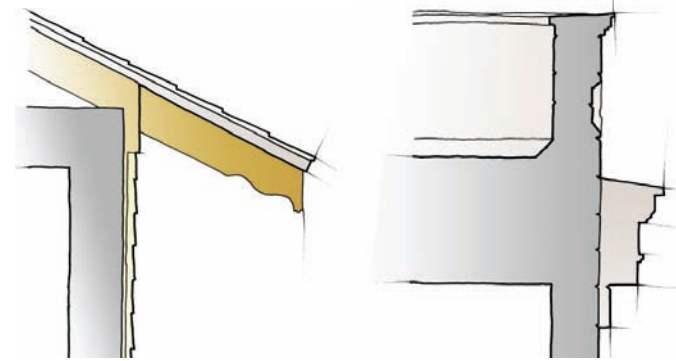

Roof and eave details connect the built structure to the open sky. Detailed brackets, beams, rafters, decorated cornices and fascias are highly encouraged. The following guidelines should be considered:

Single family housing may have lighter details. The materials can be less durable and heavier than those of a Civic Building. All sloped roofs should not be less than 5:12 -please consult the Building Official for more information; Porches may have a gentler slope -for more details refer to Article 5 of the SmartCode for the City of D'iberville.

Multi-family and mixed-use buildings should have more durable materials. As in the single family, the roof slope should be no less than 5:12.

Parapets are typically used to hide flat roofs in mixed use buildings. The parapets must be tall enough to cover from public scrutiny any type of equipment located on the roof. Parapets should add to the overall decoration of a building facade.

The multi-family building below is an example of what should NOT be acceptable in the SmartCode area of the City of D'iberville. the absence of detail and parapets creates a false ending to the building. Please notice that the roof has a very low slope -not allowing for appropriate water run off.

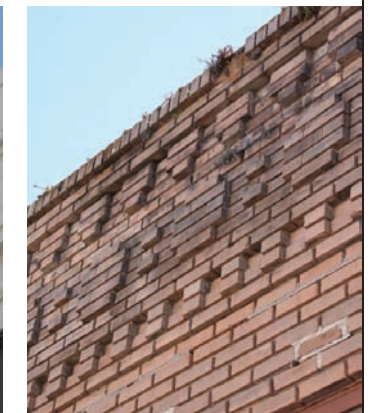

NO



ROOF MATERIALS

ROOFS

A consistency of roof materials shall provide a unified design within the SmartCode of the City of D'Iberville. The following roof materials are permitted: wood shingles, cement shingles, cement shingles, architectural shingles @ 250 pound/square, asphalt shingles, metal roofs, metal shingles, and tiles -please refer to Article 5 of the SmartCode for the City of D'Iberville for further detail and information.

The same roofing materials shall be used throughout the roof area of the same building. Slopes shall be calculated according to the material specifications and general construction standards accepted in the State of Mississippi -please refer to the Building Official for further details and information.

The roof below is patched and presents changes of color and material within the same surface. This type of configuration shall NOT be allowed within the SmartCode area of the City of D'Iberville.

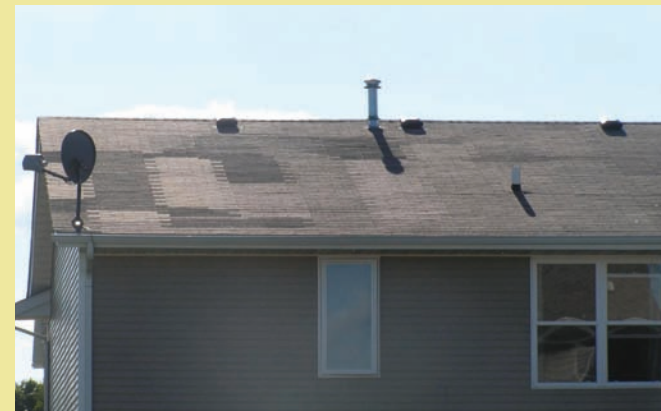

NO

